

331010 产品组合图

10mm AIR BELT SANDER

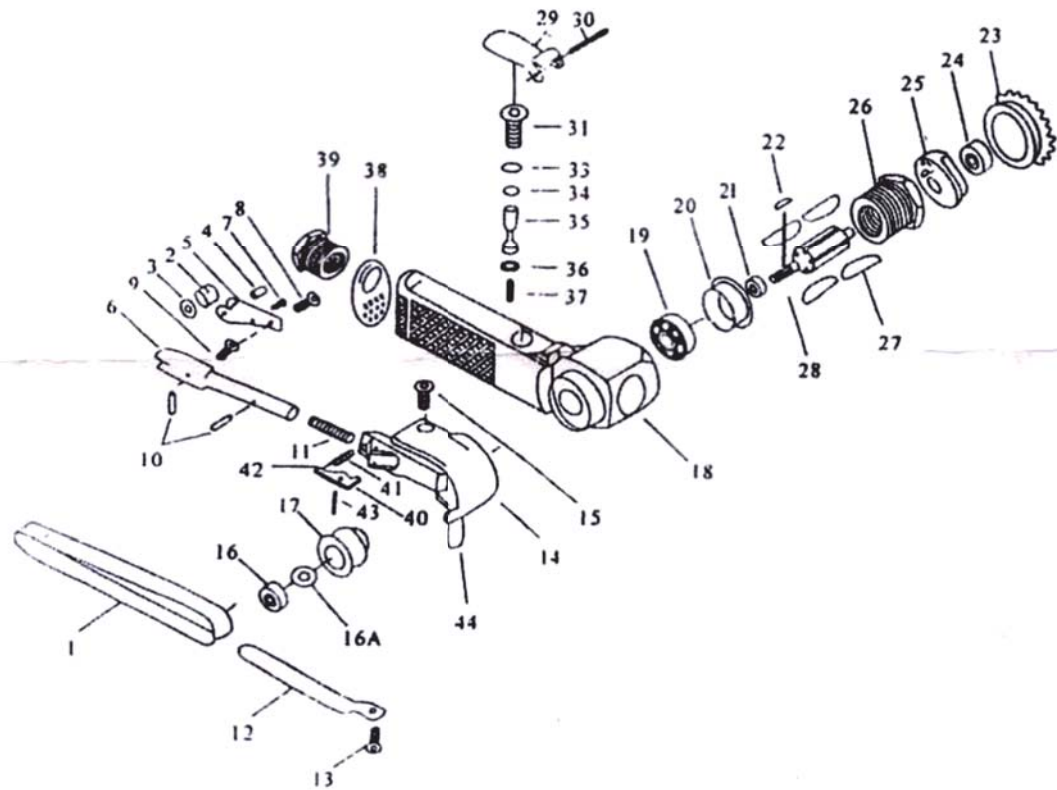

PARTS NO.	DESCRIPTION	QUANTITY	PARTS NO.	DESCRIPTION	QUANTITY
1	Grinding Belt	1	20	End Plate B	1
1A	Grinding Belt	1set	21	Spacer 8x11x3	1
1B	Grinding Belt	1	22	Sunk Key 3x3x1	1
2	Idle Pulley	1	23	Cap	1
2A	Idle Pulley	1	24	Ball Bearing 607zz	5
2B	Ball Bearing	1	25	End Plate A	1
2C	Washer	1	26	Cylinder	1
3	Washer	1	27	Blade Assy (4pc/set)	1set
4	Idle Pulley Screw	1	28	Rotor	1
5	Bracket 10	1	29	Throttle Lever	1
6	Tension Bar 10	1	30	Lever Pin	1
7	Hexagon Socket Headless Set Screw 3x10	1	31	Valve Body	1
8	Cross-Recessed Flat Head Mashine Screw 3x8	1	33	O-ring (P9)	2
9	Spring 1.0x7.2x6.5	1	34	O-ring (P5)	1
10	Spring Pin 3x10	2	35	Valve Stem	1
11	Spring 1.07x4.0x35.5	1	36	O-Ring (3.6x2.4)	1
12	Shoe 10	1	37	Valve Spring	1
13	Cross-Recessed Flat Head Mashine Screw 4x8	1	38	Deflector	1
14	Guard Sud Assy A	1	39	Air Inlet	1
14A	Guard Bushing	1	40	Tension Bar	1
15	Hexagon Socket Head Bolt 5*15	1	41	Spring	1
16	Hexagon Pulley	1	42	Lever Pin (M2x6)	1
16A	Washer	1	43	Lever Pin (M2.5x10)	1
17	Drive Pulley	1	44	Dust Cover	1
18	Housing	1	45	Hexagon Wrench Key 4	1
19	Ball Bearing 628zz	1	46	Hexagon Wrench Key 1.5	1